

## DOCUMENT RESUME

ED 082 460

EM 011 414

AUTHOR Frick, Frederick C.  
TITLE Educational Technology Program. Quarterly Technical Summary, 1 June Through 31 August 1972.  
INSTITUTION Massachusetts Inst. of Tech., Lexington. Lincoln Lab.  
SPONS AGENCY Air Force Systems Command, Washington, D.C.  
REPORT NO ESD-TR-72-233  
PUB DATE 15 Sep 72  
NOTE 20p.; See Also EM 011 411

EDRS PRICE MF-\$0.65 HC-\$3.29  
DESCRIPTORS Academic Achievement; Autoinstructional Aids; Capital Outlay (for Fixed Assets); Computer Assisted Instruction; \*Cost Effectiveness; Costs; Educational Development; Educational Technology; \*Equipment Evaluation; \*Formative Evaluation; Individualized Instruction; \*Instructional Systems; \*Instructional Technology; Low Ability Students; Microfiche; Military Training; Technical Reports; Vocational Education

IDENTIFIERS CAI; Keesler Technical Training Center; KTTC; \*Lincoln Training System 3; LTS 3; LTS 4

## ABSTRACT

Field trials of the Lincoln Training System (LTS-3) at Keesler Air Force Base were completed. Fifteen lessons on the material covered in the fifth week of an electronics course were prepared and used. Students using the LTS-3 materials learned slightly better than pupils who received conventional instruction, lower aptitude students performed well, and there was a 37% savings in time. Thus, despite higher capital costs, overall operating expenses can be reduced, and the system is cost effective. Therefore, planning for full engineering development and operational test of a production prototype system (LTS-4), in which the new training medium will be used for an entire course of instruction, was undertaken. Extensive development of lesson materials and the installation of microfiche production facilities at Keesler Technical Training Center were recommended. Hardware development activities during the quarter included: 1) microfiche selector development, 2) audio reader system development, 3) audio channel experiments, 4) data channel development, 5) a survey of high-resolution films, 6) the assembly of a system self-processor, and 7) the development of self-processor software. (Author/LB)

EDUCATION

U.S. DEPARTMENT OF HEALTH,  
EDUCATION & WELFARE  
NATIONAL INSTITUTE OF  
EDUCATION

THIS DOCUMENT HAS BEEN REPRO-  
DUCED EXACTLY AS RECEIVED FROM  
THE PERSON OR ORGANIZATION ORIGIN-  
ATING IT. POINTS OF VIEW OR OPINIONS  
STATED DO NOT NECESSARILY REPRE-  
SENT OFFICIAL NATIONAL INSTITUTE OF  
EDUCATION POSITION OR POLICY

# Quarterly Technical Summary

## Educational Technology Program

15 September 1972

Issued 2 November 1972

Prepared for the Department of the Air Force  
and the Advanced Research Projects Agency  
under Electronic Systems Division Contract F19628-70-C-0230 by

# Lincoln Laboratory

MASSACHUSETTS INSTITUTE OF TECHNOLOGY

LEXINGTON, MASSACHUSETTS

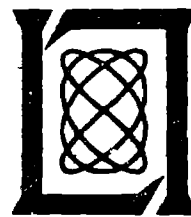

Approved for public release; distribution unlimited.

FILMED FROM BEST AVAILABLE COPY

EM 011 414

The work reported in this document was performed at Lincoln Laboratory, a center for research operated by Massachusetts Institute of Technology. This work was sponsored in part by the Department of the Air Force under Contract F19628-70-C-0230 and in part by the Advanced Research Projects Agency of the Department of Defense under Contract F19628-70-C-0230 (ARPA Order 2146).

This report may be reproduced to satisfy needs of U.S. Government agencies.

Non-Lincoln Recipients  
**PLEASE DO NOT RETURN**  
Permission is given to destroy this document  
when it is no longer needed.

## ABSTRACT

Field trials of the LTS-3 system at Keesler Air Force Base were concluded during this quarter. Results were excellent, and planning for full engineering development and operational test of a production prototype system (LTS-4) has begun. Design studies for LTS-4 continue. Active data channel measurements have been initiated.

15 September 1972

F. C. Frick  
Program Manager

Accepted for the Air Force  
Joseph J. Whelan, USAF  
Acting Chief, Lincoln Laboratory Liaison Office

# CONTENTS

Abstract	iii
Organization	vi
I. The Keesler Trial	1
A. Purpose and Main Results	1
B. Cost Benefits	1
C. Implication for an All-Volunteer Service	3
D. Further Plans	3
II. LTS-4 Hardware Development	5
A. Fiche Selector Development	5
B. Audio Reader System Development	6
C. Audio-Channel Experiments	7
D. Data-Channel Development	7
E. Film Considerations	11
F. System Self-Processor	11
G. Self-Processor Software Development	12

# ORGANIZATION

## EDUCATIONAL TECHNOLOGY PROGRAM

### PROGRAM MANAGER

F. C. Frick

### DIVISION 2

#### Technical Staff

Brown, J. R.  
Butman, R. C.  
Goodman, L. M.  
Grossberg, M.  
Harris, W. P.  
Karp, D.  
LaFrey, R. R.  
Mayer, R.  
McLaughlin, A. J.  
Peterson, H. C.

#### Assistants

Gagnon, J. V.  
Hallowell, L. F.  
Pugh, Barbara K.  
Ray, D. J.

#### Technicians

Delsie, J. V.  
Edman, E. W.  
Johnson, P. J.  
Ritchie, J. R.

#### Photographer

Recke, R. F.

# EDUCATIONAL TECHNOLOGY PROGRAM

## I. THE KEESLER TRIAL

### A. Purpose and Main Results

A formal test of the Lincoln Training System (LTS) at the Air Force Keesler Technical Training Center has been completed. The purpose was to assess the potential of the LTS as a component in a technical training school. It was expected that the LTS would support student learning at a significantly increased rate, with no loss of proficiency, and with less demand on the teaching staff when compared with conventional classroom techniques.

Fifteen lessons were prepared for LTS-3 covering the fifth week of the ATC Standardized Electronic Principles Course, analysis of series and parallel RCL circuits. The lesson frames, including visual images, audio-messages, and control logic tables, were developed by instructors of the 3380th Technical School at Keesler. Performance of 55 regular students in Electronics, each working individually at a Lincoln Terminal, was compared with another group that covered the same ground in a conventional classroom setting. The LTS and classroom groups did not differ significantly in General, Mechanical, Electronic, and Administrative scores on the Airman Qualification Examination. Three tests on the week's material were given: at the end of the training, at the end of the Block (after one week of further training), and six weeks later. As shown in Table I, there are no important differences in performance between groups. The

Group	Time of Test		
	End-of-Week*	One Week*	Six Weeks†
LTS	79.9	78.8	82.8
Conventional	77.0	78.5	77.2

\* N = 55, full group.  
† Data available for only 20 students in LTS and 19 in conventional groups.

distribution of total lesson completion times for the LTS group is shown in Fig. 1. Note that there is a 37-percent savings in time and that 53 of 55 airmen finished in less than the normal allotment of 30 hours for classroom instruction. The main result of the study is the demonstration of a large savings in training time without loss in achievement of the lesson objectives.

### B. Cost Benefits

Use of the LTS as a component in training has fairly radical system effects. The instructor is replaced by a tutor/manager; the development of lessons is more elaborate and requires new

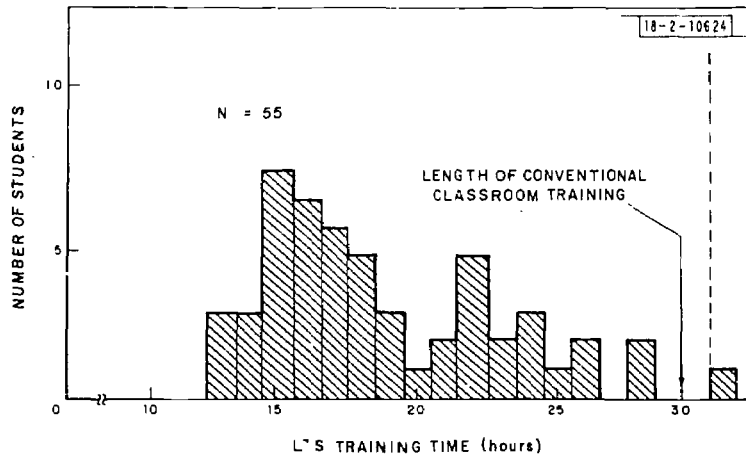

Fig. 1. Distribution of LTS training time. (One subject required 59 hours to complete training and is not shown in above distribution.)

author skills; and the addition of terminals implies new capital and operational expenses. The Keesler Trial provides experience that suggests the nature and rough magnitude of the problems and costs involved.

The lesson development process was relatively straightforward. The authors were experienced instructors, and with a few days of indoctrination were able to begin lesson development. Diagrams and text were adapted from conventional materials. The authors themselves wrote out and recorded the audio and specified the table of data that conditioned the computer branching on each frame. The equipment to produce master fiche involved a one-time capital cost of about \$50,000, and the operating expenses - photography, processing, copying, filing, etc. - were comparable to those involved in other media, e.g., texts, sound slides, and CAI. The well-known economy of fiche in all respects - storage, reproduction, and dissemination - was confirmed in the LTS application. All lesson development costs, plus the cost of terminals themselves, are capital expenditures which, in the long run, may be amortized over the thousands of students per year in large training programs. Exact figures on these costs cannot be derived from operation of LTS-3 because the equipment and techniques are experimental in nature, but the experience has shown that capital investment in lesson materials is not strikingly different from current lesson costs. The development of less expensive, more reliable, and equally versatile terminals remains as the primary need in order to realize an economical system.

The role of the LTS student monitor is different from the classroom instructor: he both instructs, i.e., tutors slow students, and also gives course guidance, i.e., checks on student progress. In the Keesler Trial, 1.4 percent of the LTS student's time in class was occupied in one-on-one tutoring. Also, since each lesson made knowing the material an easier way to progress than guessing, the monitor was assured that a student who finished a lesson had a fair mastery of it. Under these conditions, at least 24 students can be managed by one person, giving the LTS an advantage over conventional training with regard to student/staff ratio. In other respects, the conditions that might affect system operational costs are very much the same.

In summary, the initial one-time costs of LTS software and hardware are likely to be somewhat higher than those of conventional instruction, and the operational costs per student per hour of training appear to be comparable. Under these circumstances, even moderate savings in



total training time translate into savings in costs. For example, in the prior Quarterly Technical Summary,\* we reported that a 36-week course with 1800 students per year at KTTC costs \$30M per year. A one-third reduction in average training time for this course would balance off all costs - development hardware, lessons, etc. - in the first year. We conclude that a moderate increase in the capital expense involved in application of the LTS can result in large savings in the cost of operating a training school.

### C. Implication for an All-Volunteer Service

Airmen selected for this course score 80 or more on the Electronics section of the AQE. The top 20 percent of these students were assigned to a self-paced learning group and were excluded from the current study. Despite these restrictions on the range of students, there is clear evidence that slower students received extra benefits from LTS training. During the course of the Trial, three facts were noted: (1) the LTS students of lower aptitude spent more time in training than those of higher aptitude, (2) the lessons provided immediate feedback tailored for each kind of error, and (3) LTS freed the instructor to concentrate his efforts on tutoring slow students. For these reasons, the correlation between aptitude and the achievement test score was much lower for LTS ( $r = 0.22$ ) than for classroom training groups ( $r = 0.53$ ). Also, there were fewer failures, i.e., scores below 60, among the LTS students in comparison with the classroom group. Note though in Fig. 1 that even the slow students saved time.

Each student in the LTS group filled in a 21-item attitude survey on this form of training. The main results were that 88 percent of the responses were favorable, 7 percent neutral, and 5 percent unfavorable. Informal written comments revealed a strong preference for LTS training. These results are consistent with the kind of student enthusiasm often shown for effective CAI systems.

The significance of the findings concerning the compensatory nature of the training and its attractiveness to the airmen are important with respect to an all-volunteer force in which some decrease in prior schooling and aptitude of personnel is expected.

### D. Further Plans

The overall results of the Keesler Trial have encouraged the Project to pursue the development of a stand-alone, table-top model - LTS-4. The experience with LTS-3 largely confirms the adequacy of the design as a training-system component. However, a redesign of the hardware realization of the concept is needed. The reliability of LTS-3 (3.2 percent down time) is not adequate. A few students complained in their survey responses that occasionally there was excessive dust on the pictures, noise in the audio, and delays in calling up new frames. LTS-4 will be improved in all these respects.

As a consequence of this study, the 3380th Technical School has proposed an operational test with LTS as the training medium in whole courses of instruction.† To this end, they recommend (1) development of LTS-4, (2) extensive development of lesson materials at KTTC, and

---

\* Educational Technology Program, Quarterly Technical Summary, Lincoln Laboratory, M.I.T. (15 June 1972), DDC AD-747013.

† W. P. Harris, et al., "Keesler Test of Lincoln Training System (LTS) Feasibility," Project Report 72-112, Keesler Technical Training Center, Keesler Air Force Base (31 July 1972).

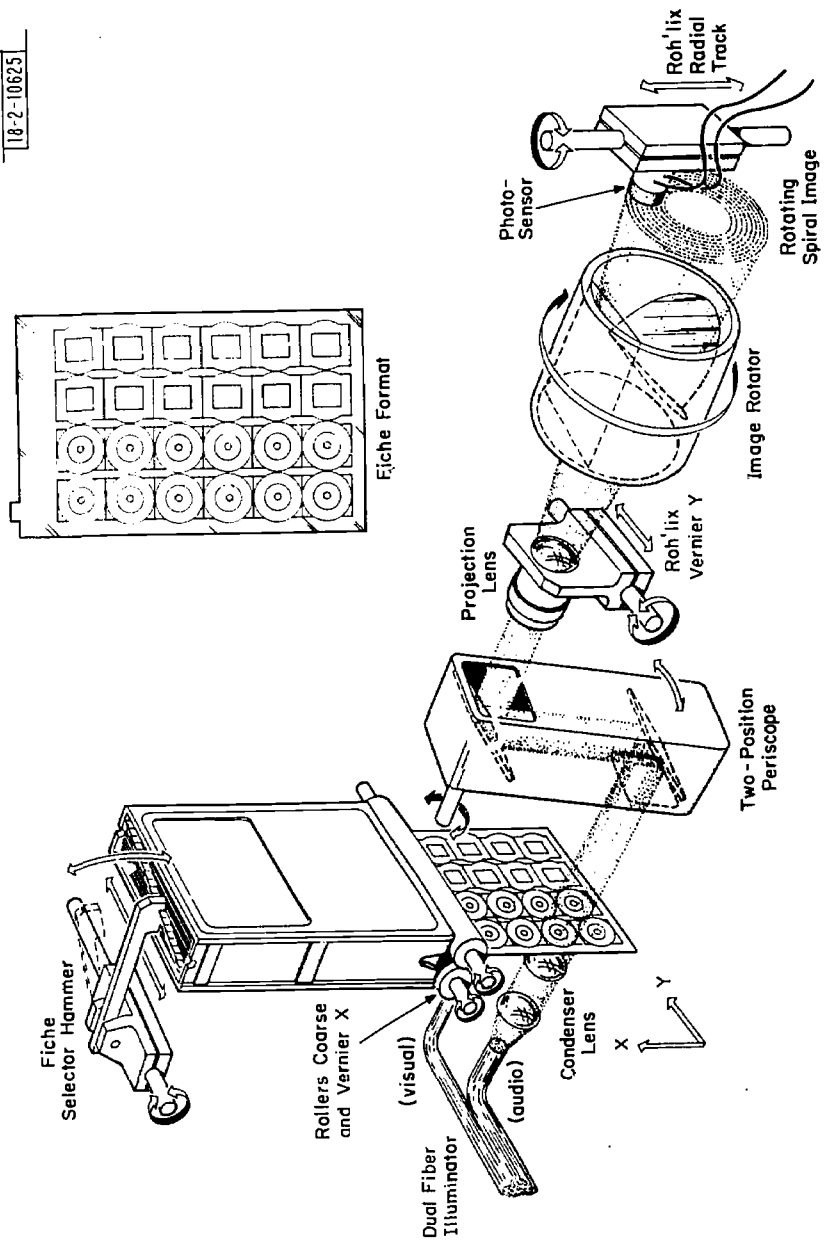

Fig. 2. LTS-4 reader concept.

(3) installation of fiche production facilities at Keesler. Because of the stand-alone nature of the LTS-4 design and because of the low rate of instructor/student interaction observed in the Trial, they further recommended that a test of LTS for Career Development Courses at operational sites be conducted. We plan a large-scale operational test of the LTS in school and on the job when LTS-4 is available.

## II. LTS-4 HARDWARE DEVELOPMENT

During this quarter, a study of microfiche reader/selector techniques was undertaken with Arthur D. Little, Inc. to establish a cost-effective design which will make practical the large-scale deployment of LTS stand-alone terminals. As a result, a system has been configured using an image rotator and a linear actuator to achieve a scan of the audio spiral track. The fiche selector mechanism is comprised of a cassette for storage, and stepper motors and rollers to achieve a simple extraction scheme.

The compandor and AVC described in the previous Quarterly Technical Summary (15 June 1972) have been used to record spirals which have, in turn, been played back in a series of tests to establish listener acceptance of the techniques and to demonstrate reduction in background impulse noise.

A data modulator has been built and, in conjunction with a PDP-8/L, will be used to format and condition data for the spiral recording facility. A data demodulator has also been built, and a series of back-to-back system tests have been completed. We are currently conducting tests with data on film to verify system performance.

Work continues on the development of color-film recording techniques in an attempt to isolate a single color layer and thereby achieve a higher resolution for the audio/data channel.

The Intel MCS-4 Micro Computer Set continues to appear plausible as a processor for the stand-alone terminal. A SIM4-02 Computer Prototyping Kit and a MP7-02 PROM Programmer have been delivered. These system components, along with an interface, are being wired together to provide a means of simulating an MCS-4 system. Test I/O programs have been written using MCS-4 code and will be used to exercise the data modem.

### A. Fiche Selector Development

Evaluation of a commercial 30-fiche cassette visual reader has been completed. We will use the cassette and fiche selection/extraction subassemblies in the LTS-4 breadboard reader.

The LTS-4 fiche selector design concept is shown in Fig. 2. Upon receipt of a fiche and frame selection command, a selection hammer drives 1 of 30 fiche out of the cassette and against pinch rollers. The stepper motor-actuated rollers drive the fiche at high speed until the desired row is coarsely centered in the audio and visual projection gates. Simultaneously, the periscope is rotated to select the desired column. Fine registration then begins by measurement of the X-Y position error using a boresight target. Y-axis correction is accomplished by stepper motor vernier movement of the projection lens assembly. X-axis correction results by engaging, through clutches, a gear reduction for vernier stepper motor motion of the rollers. When acceptable registration is accomplished, the positioning system is disabled and the frame is read. The expected final registration error is  $\pm 0.050$  mm in either axis. Since the X-Y measurement

will be made in the image plane, the use of the image rotator described later requires synchronous measurement of position to derive coherent correction signals.

An alternate method of fine registration might consist of taper pins located in the film gate, with precision holes in the envelope and fiche. Since the fiche-centering servo represents an expensive component of the LTS-3, it would be desirable to eliminate it by locating the fiche to the necessary accuracy more directly. The center of the audio record must be located accurately enough to center its image on the bearing axis of the Dove assembly to minimize the  $2\omega$  error (see discussion of Dove assembly alignment in Sec. B below). However, shifts in other components due to temperature, handling, or age can also cause the image to shift off the bearing axis. At present, a servo system can compensate for all these errors to the accuracy of that servo system, independent of the source of the error, providing that its detector remains accurately centered on the bearing axis of the Dove assembly.

An analysis is being made presently of the sources and magnitudes of all the errors which cause the center of the audio record to shift with respect to the bearing axis of the Dove assembly in the plane of the scanner.

## B. Audio Reader System Development

Early in this quarter, a set of detailed guidelines was developed in order to define reader system design goals for LTS-4. The guidelines formed the basis of the Arthur D. Little Phase I study (June-July), which culminated in a reader design which will be fabricated by January 1973.

The general approach to the design of the audio reader has been to decouple as many functions as possible. As a result, the image rotation concept, which separates the rotational and radial motions, was selected.

The reader concept, shown in Fig. 2, consists of a condenser system, projection system, image rotator, and optical sensor assembly (OSA) mounted on a radial drive. The image rotator causes the spiral image to revolve at twice the angular velocity of the rotator.

The errors introduced by the rotating Dove assembly are of two kinds: those rotating at the rate the Dove turns ( $\omega$ ), and those rotating at twice the rate the Dove turns ( $2\omega$ ). The  $\omega$  errors are caused by misalignment of the Dove assembly with respect to its bearing axis, while the  $2\omega$  errors are caused by the center of the record disk not being imaged on the same bearing axis at image plane.

Thus, the  $2\omega$  error of the system is the error introduced by the fiche-centering servo system, and depends only upon the accuracy of that system.

In the present concept of the Dove assembly, the  $\omega$  error caused by the alignment errors of the Dove assembly can be completely removed to the accuracy of the power of the microscope used during the alignment procedure by adjusting only one of the three mirrors of the assembly. The remaining error introduced by the Dove assembly, a tilt of the image plane which rotates at  $\omega$ , can be minimized to be negligible by a simple manufacturing technique during the machining and assembly of the rotating mirror cage.

An alternate method of reading the fiche can be implemented in the image rotator reader. A light-emitting-diode (LED) aperture, mounted in place of the OSA, would be imaged in the reverse direction on the film. The transmitted light, when collected by a large diode (in place of the condenser system), would provide the output audio signal.

Samples of a commercially available 28-mm photodiode have been procured. Tests and analysis indicate that it should be an acceptable detector for the alternate system. Samples of small-aperture LEDs are being procured for test and analysis.

### C. Audio-Channel Experiments

To reduce background impulse noise, a syllabic rate speech compressor and expander (compandor) has been designed for use with the LTS audio channel. This technique requires that each LTS terminal be equipped with an expander which has a small quantity parts cost of under \$25. In addition, to maintain a sufficient average signal level without distortion due to clipping, an automatic volume control (AVC) has been implemented as part of the LTS author recording facility. In order to evaluate subjectively the effect of companding and AVC, a listening test was devised. A number of speakers each recorded an audio segment onto a tape recorder. Each speaker's segment was then recorded onto film and played back over LTS-3 in three different ways: first, no processing; second, companding only; and finally, AVC and companding. In all three techniques, the record level was set so that peak speech was just below the system clip level. A group of listeners were then asked to evaluate each set of recordings for each speaker by stating their personal preferences. The results of the test show that, averaged over all speakers, all listeners substantially preferred companded speech to noncompanded speech, and that most of the listeners showed a slight preference for the speech that was recorded through the AVC.

### D. Data-Channel Development

A facility has been implemented for recording digital data on the LTS audio spiral on the beginning of the track prior to the voice information. A block diagram of this system is shown in Fig. 3. Data for each frame are stored in the PDP-8/L computer where they are encoded and placed in the proper format for transmission. The modulator uses binary phase-shift keying and sends one cycle of a sine wave for each data baud. For each frame, the computer initially sends the data, and at the conclusion of data turns on the tape recorder to transmit the voice signal through the data/voice multiplex.

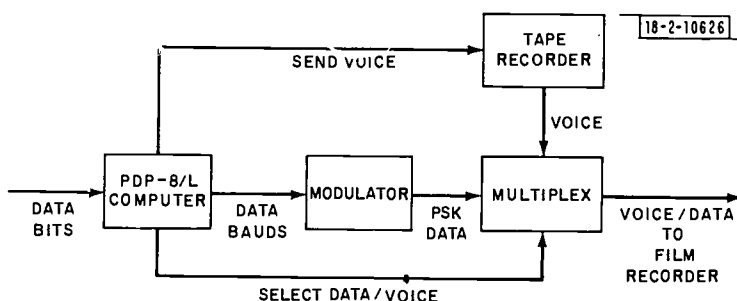

Fig. 3. Data/voice merge facility.

At present, 200 bits of data are encoded using a simple triple-repeat code in blocks of 8. For the demodulator to acquire baud and block synchronization, a preamble must be transmitted. Six synchronization blocks of 23 zeros and a one are sent for block framing, plus an additional six blocks to acquire baud synchronization. Also, a number of synchronization blocks equal in time to the total initial track uncertainty, plus reader acquisition time, are

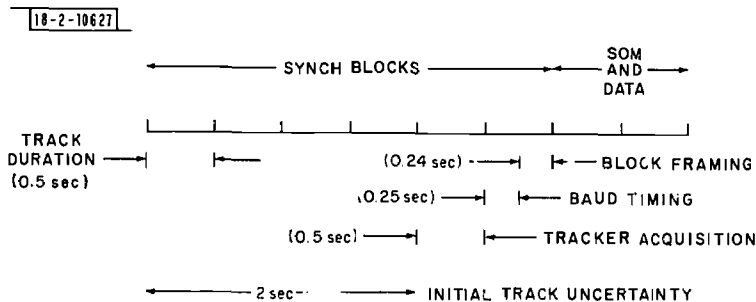

Fig. 4. LTS transmission format (600 bauds).

recorded. To indicate the end of preamble and beginning of data, a start-of-message (SOM) character (8 bits) is sent. The total LTS transmission format is shown in Fig. 4 for the case of 600 bauds.

A test program called "Filmit" has been written for the PDP-8/L computer to output serial data on command via BA C4 of I/O channel 34. The data-block portion of the serial transmission is manually loaded into the PDP-8/L via the teletypewriter, and data are formatted as described above. The entire data frame, including the preamble, is stored in a 321-word buffer from which it is presented one bit at a time (most-significant bit first) to the output interface on external command.

An LTS-3 has been modified so that branching information, which is currently stored on a magnetic-tape unit, can be stored on and read directly from film. The modification basically entails the addition of a data-control signal from the computer, a PSK demodulator, and a serial interface to the computer. The PSK demodulator detects the baud information from the modulated audio signal and acquires baud synchronization. The computer obtains block synchronization, detects the SOM signal, and decodes the data from the incoming baud stream. A functional block diagram of the demodulator is shown in Fig. 5. The demodulator consists of a squarer, phase-lock loop, and divide-by-two network to obtain basic timing and a reference signal. An integrate and dump matched filter receiver is used for baud detection. A flow chart of the demodulation-decoding process is shown in Fig. 6.

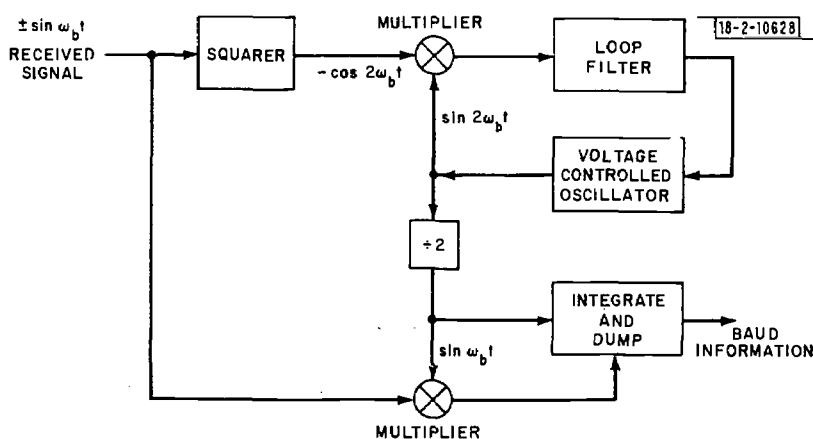

Fig. 5. PSK demodulator.

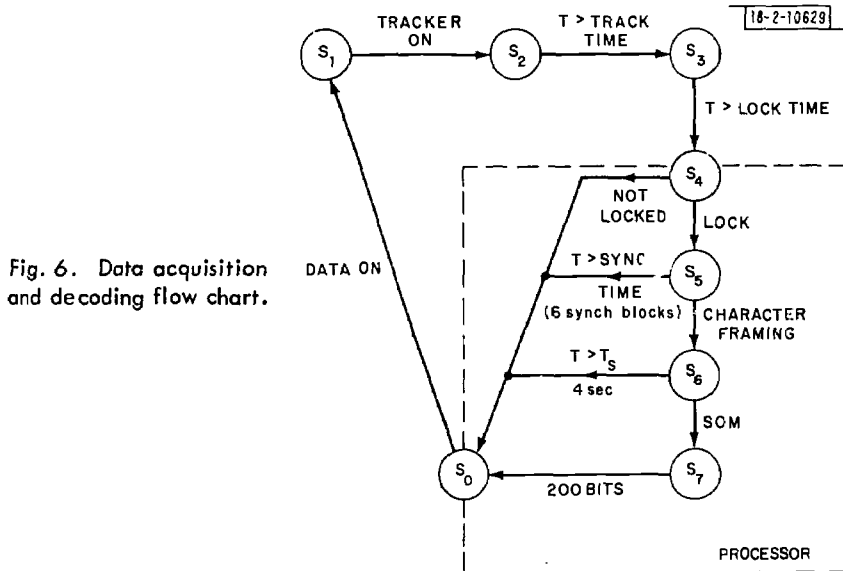

Fig. 6. Data acquisition and decoding flow chart.

As a subroutine to the LTS-3 "Card Reader Cycle" program, a "Readfilm Test" program was written to receive, analyze, and print out PSK demodulated serial data received via a PDP-8/I I/O channel. The data blocks, associated with each fiche frame, are composed of 243 words of preamble coded to establish word frames, an SOM bit sequence, and 25 words of triple-repeated-coded data. During the preamble transmission, the computer establishes word framing, and upon detection of start of message the program decodes (8-bit) words by making a majority decision of three successive word frames. As each triple-word frame is received, it is compared with each of the three known data-repeated words to determine baud errors, and another comparison is made with the 2/3 majority extraction for data bit errors. A running total of data frames and the above error counts are tabulated in the computer and typed on the TTY.

Data have been recorded onto film and read successfully by the data modem into the PDP-8/I computer. Initial results for 200 bits/sec (600 bauds) indicate a bit error rate of less than  $10^{-8}$ .

Incidental FM causes the phase-locked loop to be more susceptible to loss of lock when multiplicative dropouts occur. To hold within the linear region of the loop-phase-error detector, the phase error must be less than  $30^\circ$ . For the case of high signal-to-noise ratio, the maximum allowable percent FM at a modulation frequency of 2 Hz is plotted vs the burst-error duration in Fig. 7.

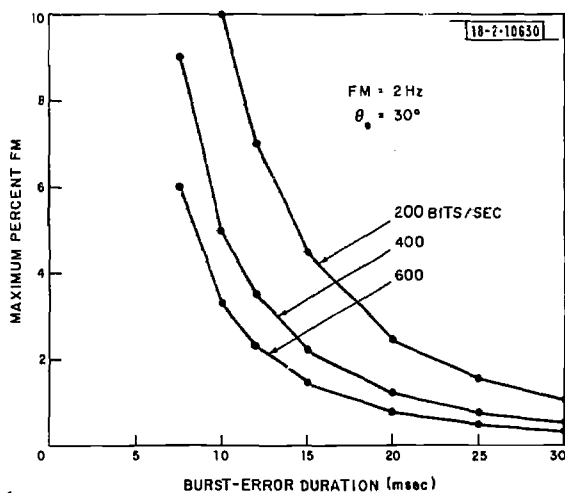

Fig. 7. Maximum percent FM vs dropout time.

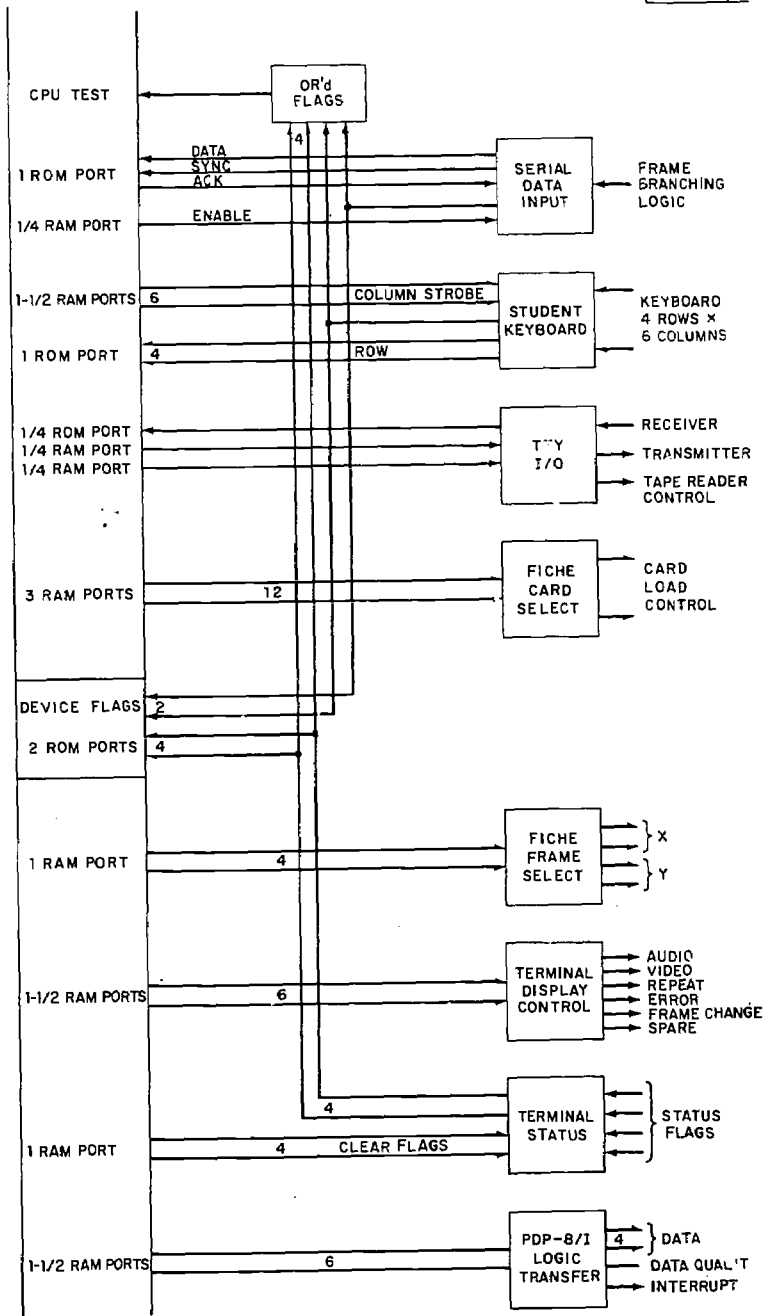

Fig. 8. SIM4-02 I/O interface block diagram.



## E. Film Considerations

A comprehensive survey of high-resolution films continues. Kalvar type 200, recently made available, will provide improved high-frequency characteristics when used as the distribution fiche.

Kalvar and Diazo printing and developing capabilities have been procured to allow complete control of fiche production during terminal and film development.

Color fiche experiments, designed to exploit the higher resolution of the individual dye layers, continue. Color subtractive filters and special illumination sources have been procured.

Modifications have been completed which permit the recording of data-modem signals on fiche. Test samples on master and distribution fiche film are being processed for evaluation. Color fiche having data spirals will also be evaluated.

## F. System Self-Processor

The Intel SIM4-02 microcomputer system components were procured during the past quarter, and hardware assembly was started. An MP7-02 programming module is used with the simulator to code the programmable read-only memory modules (PROMs).

When assembled, the SIM4-02 with 16-each Intel 4001 RAMs and 13-each 1702 PROMs will give 5 kbits of RAM and over 26 kbits of programmable ROM. Coding of the PROMs will be accomplished through an ASR33 teletype. Erasure of PROMs will be accomplished by the use of a high-intensity ultraviolet light source.

The SIM4-02 microprogrammable computer will be used to design a prototype LTS-4 digital self-processor. Input/output communication with the SIM4-02 will be accomplished through ROM and RAM I/O "ports," which are used to route information to or from the internal data bus lines, in or out of the system. Each RAM chip contains a 4-bit output port. The ROM I/O port functions are simulated by gates and bistable latches. The reason for the simulated ports is that the PROMs, used in the SIM4-02, do not have built-in I/O port logic. It was therefore necessary to simulate the "port" function for the prototype system.

In the following discussion, LTS-4 terminal hardware mechanisms such as student keyboard, serial data modem, fiche loading, and frame slewing mechanism, etc., will be referred to as I/O "devices." An output port can be thought of as a 4-bit parallel storage register, loaded under control of the SIM4-02 CPU, and an input port as a set of 4 gates, again controlled (strobed) by the CPU. A block diagram of the proposed interface is shown in Fig. 8. Each bit of an I/O device will occupy a separate ROM or RAM port line. This simplifies the interface logic greatly, and makes the most efficient use of available hardware. As shown in the figure, the interface will communicate with existing devices using 10 of the available 16 RAM ports and 4 of the available 13 ROM ports. Two ROM ports (8 lines) are reserved for monitoring input device flags which are also OR'd to the common CPU TEST line.

The SIM4-02 processor does not have an interrupt capability as such. However, it does have a TEST line into the CPU, the state of which can control one of the conditions in the processor's JCN (jump conditional) instruction. By "OR"ing all input device flags onto the TEST line, the CPU periodically tests the line to see if an input device is waiting for service. At this point, the processor can scan the two ROM ports containing the individual device flags to determine which device is in need of service or is indicating completion of an operation. In this way, a program-controlled interrupt capability can be simulated.

The six output lines labeled "Terminal Display Control" will be used to control audio, video, frame repeat or reset, and other terminal hardware control functions.

The PDP-8 logic output will be used as a means of communication between the SIM4-02 and the PDP-8/I computer. This link will be used for preliminary checkout of the SIM4-02 as an LTS-4 digital processor. Six lines are used for this device - two lines for control, and four for parallel data transfer.

### G. Self-Processor Software Development

An LTS-3 Author Program (ANYORD) was encoded to check the feasibility of encoding student response routines on the MCS-4 processor. The result suggests that all such LTS-3 programs currently in use could probably be encoded and run in the MCS-4.

Several system control programs were encoded so that an actual test of the MCS-4 computer can commence:

MAIN	This program initializes those parts of the system that the MCS-4 reset does not affect. It then waits for an input device to indicate that there is an input to be processed, and calls CHKI/O to process it.
CHKI/O	This program determines which device is asking for attention and calls the appropriate program to process it. Upon return from either the keyboard or logic program, data are sent to the PDP-8. Currently, the only devices recognized are KEYBOARD, LOGIC, and CLOCK. However, five more devices can be accommodated.
LOGIC	This program detects sync and start of message, stores the data and checks for a proper sumcheck and an end-of-message flag.
KEY	This program strobes the keyboard and converts the key push to a number between 0 and 31, stores the result in registers 0 and 1, and returns to the CHKI/O program.

The Editor on the IBM 360 is used to generate the MCS-4 source code. A routine punches the paper tape used by the PDP-8/I assembler to generate binary code. These facilities will be used extensively in the development of the control routines and a new LTL for keyboard interpretation.

**DOCUMENT CONTROL DATA - R&D**

*(Security classification of title, body of abstract and indexing annotation must be entered when the overall report is classified)*

1. ORIGINATING ACTIVITY (Corporate author) Lincoln Laboratory, M. I. T.		2a. REPORT SECURITY CLASSIFICATION Unclassified	
		2b. GROUP None	
3. REPORT TITLE Educational Technology Program			
4. DESCRIPTIVE NOTES (Type of report and inclusive dates) Quarterly Technical Summary, 1 June through 31 August 1972			
5. AUTHOR(S) (Last name, first name, initial) Frick, Frederick C.			
6. REPORT DATE 15 September 1972		7a. TOTAL NO. OF PAGES 20	7b. NO. OF REFS 2
8a. CONTRACT OR GRANT NO. F19628-70-C-0230		9a. ORIGINATOR'S REPORT NUMBER(S) Educational Technology Program QTS, 15 September 1972	
b. PROJECT NO. 649L		9b. OTHER REPORT NO(S) (Any other numbers that may be assigned this report) ESD-TR-72-233	
c. ARPA Order 2146			
d.			
10. AVAILABILITY/LIMITATION NOTICES Approved for public release; distribution unlimited.			
11. SUPPLEMENTARY NOTES None		12. SPONSORING MILITARY ACTIVITY Air Force Systems Command, USAF Advanced Research Projects Agency, Department of Defense	
13. ABSTRACT  Field trials of the LTS-3 system at Keesler Air Force Base were concluded during this quarter. Results were excellent, and planning for full engineering development and operational test of a production prototype system (LTS-4) has begun. Design studies for LTS-4 continue. Active data channel measurements have been initiated.			
14. KEY WORDS  educational technology Lincoln Training System (LTS)  microfiche production computer-aided instruction			